

Thermal Techniques in Measurement and Control Circuitry

Jim Williams

Designers spend much time combating thermal effects in circuitry. The close relationship between temperature and electronic devices is the source of more design headaches than any other consideration.

In fact, instead of eliminating or compensating for thermal parasitics in circuits, it is possible to utilize them. In particular, applying thermal techniques to measurement and control circuits allows novel solutions to difficult problems. The most obvious example is temperature control. Familiarity with thermal considerations in temperature control loops permits less obvious, but very useful, thermally based circuits to be built.

Temperature Controller

Figure 1 shows a precision temperature controller for a small components oven. When power is applied, the thermistor, a negative TC device, is at a high value. A1

saturates positive. This forces the LT3525A switching regulator's output low, biasing Q1. As the heater warms, the thermistor's value decreases. When its inputs finally balance, A1 comes out of saturation and the LT3525A pulse-width modulates the heater via Q1, completing a feedback path. A1 provides gain and the LT3525A furnishes high efficiency. The 2kHz pulse-width modulated heater power is much faster than the thermal loop's response and the oven sees an even, continuous heat flow.

The key to high performance control is matching the gain-bandwidth of A1 to the thermal feedback path. Theoretically, it is a simple matter to do this using conventional servo-feedback techniques. Practically, the long time constants and uncertain delays inherent in thermal systems present a challenge. The unfortunate relationship between servo systems and oscillators is very apparent in thermal control systems.

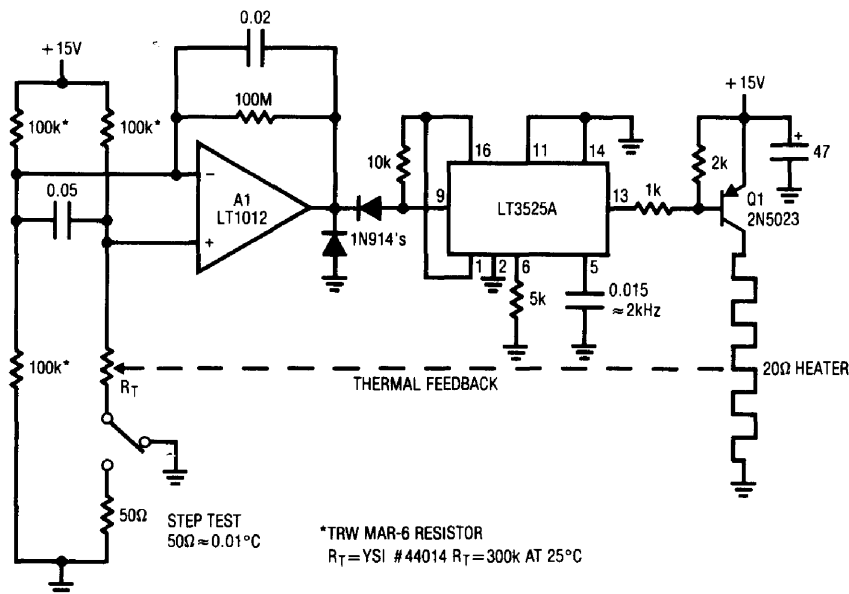

Figure 1. Precision Temperature Controller

Application Note 5

The thermal control loop can be very simply modeled as a network of resistors and capacitors. The resistors are equivalent to the thermal resistance and the capacitors equivalent to thermal capacity. In Figure 2 the heater, heater-sensor interface, and sensor all have RC factors that contribute to a lumped delay in the ability of a thermal system to respond. To prevent oscillation, A1's gain-bandwidth must be limited to account for this delay. Since high gain-bandwidth is desirable for good control, the delays must be minimized. The physical size and electrical resistivity of the heater selected give some element of control over the heater's time constant. The heater-sensor interface time constant can be minimized by placing the sensor in intimate contact with the heater.

The sensor's RC product can be minimized by selecting a sensor of small size relative to the capacity of its thermal environment. Clearly, if the wall of an oven is 6" thick aluminum, the tiniest sensor available is not an absolute

necessity. Conversely, if one is controlling the temperature of a 1/16" thick glass microscope slide, a very small sensor (i.e., fast) is in order.

After the thermal time constants relating to the heater and sensor have been minimized, some form of insulation for the system must be chosen. The function of insulation is to keep the loss rate down so the temperature control device can keep up with the losses. For any given system, the higher the ratio between the heater-sensor time constants and the insulation time constants, the better the performance of the control loop.

After these thermal considerations have been attended to, the control loop's gain-bandwidth can be optimized. Figures 3A, 3B, and 3C show the effects of different compensation values at A1. Compensation is trimmed by applying small steps in temperature setpoint and observing the loop response at A1's output. The 50Ω resistor and

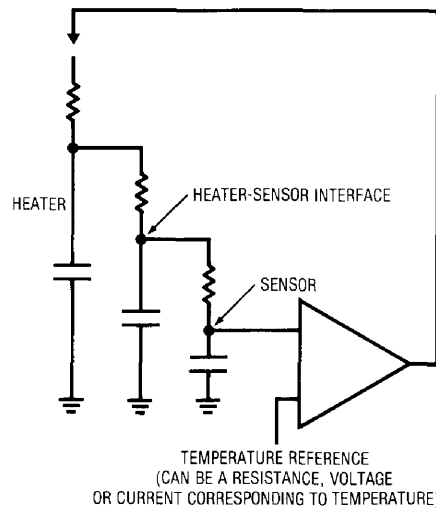

Figure 2. Thermal Control Loop Model

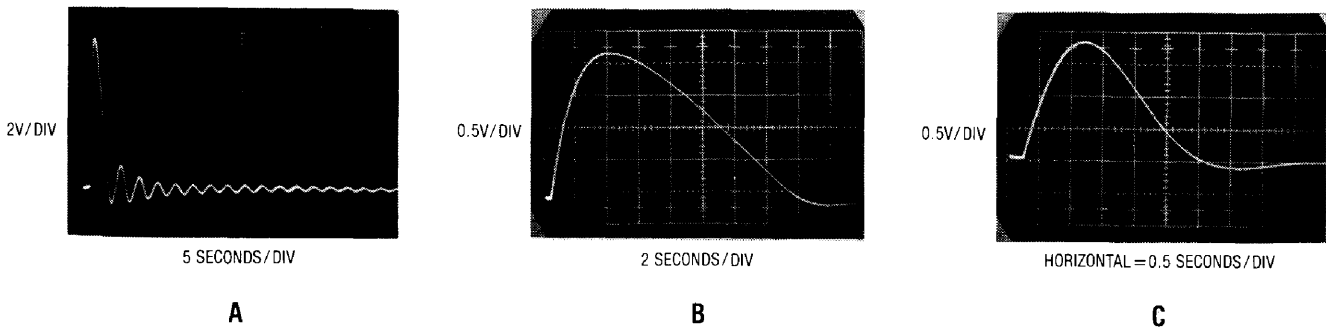

Figure 3. Loop Response for Various Gain Bandwidths

switch in the thermistor leg of the bridge furnish a 0.01°C step generator. Figure 3A shows the effects of too much gain-bandwidth. The step change forces a damped, ringing response over 50 seconds in duration! The loop is marginally stable. Increasing A1's gain-bandwidth (GBW) will force oscillation. Figure 3B shows what happens when GBW is reduced. Settling is much quicker and more controlled. The waveform is overdamped, indicating that higher GBW is achievable without stability compromises. Figure 3C shows the response for the compensation values given and is a nearly ideal critically damped recovery. Settling occurs within 4 seconds. An oven optimized in this fashion will easily attenuate external temperature shifts by a factor of thousands without overshoots or excessive lags.

Thermally Stabilized PIN Photodiode Signal Conditioner

PIN photodiodes are frequently employed in wide range photometric measurements. The photodiode specified in Figure 4 responds linearly to light intensity over a 100dB

range. Digitizing the diode's linearly amplified output would require an A-D converter with 17 bits of range. This requirement can be eliminated by logarithmically compressing the diode's output in the signal conditioning circuitry. Logarithmic amplifiers utilize the logarithmic relationship between V_{BE} and collector current in transistors. This characteristic is very temperature-sensitive and requires special components and layout considerations to achieve good results. Figure 4's circuit logarithmically signal conditions the photodiode's output with no special components or layout.

A1 and Q4 convert the diode's photocurrent to a voltage output with a logarithmic transfer function. A2 provides offsetting and additional gain. A3 and its associated components form a temperature control loop which maintains Q4 at constant temperature (all transistors in this circuit are part of a CA3096 monolithic array). The $0.033\mu\text{F}$ value at A3's compensation pins gives good loop damping if the circuit is built using the array's transistors in the locations shown. These locations have been selected for optimal control at Q4, the logging transistor. Because of the

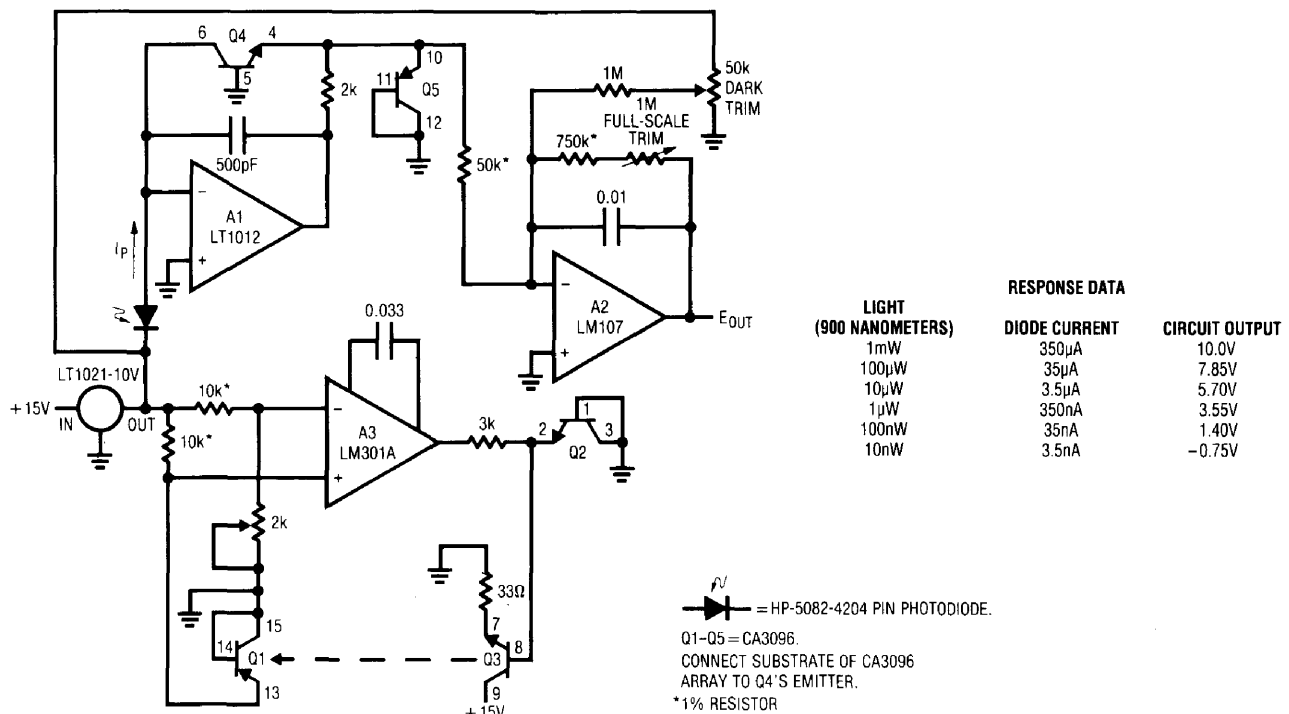

Figure 4. 100dB Range Logarithmic Photodiode Amplifier

Application Note 5

array die's small size, response is quick and clean. A full-scale step requires only 250ms to settle (photo, Figure 5) to final value. To use this circuit, first set the thermal control loop. To do this, ground Q3's base and set the 2k pot so A3's negative input voltage is 55mV below its positive input. This places the servo's setpoint at about 50°C (25°C ambient + 2.2mV/°C × 25°C rise = 55mV = 50°C). Unground Q3's base and the array will come to temperature. Next, place the photodiode in a completely dark environment and adjust the "dark trim" so A2's output is 0V. Finally, apply or electrically simulate (see chart, Figure 4) 1mW of light and set the "full-scale" trim for 10V out. Once adjusted, this circuit responds logarithmically to light inputs from 10nW to 1mW with an accuracy limited by the diode's 1% error.

50MHz Bandwidth Thermal RMS → DC Converter

Conversion of AC waveforms to their equivalent DC power value is usually accomplished by either rectifying and averaging or using analog computing methods. Rectification-averaging works only for sinusoidal inputs. Analog computing methods are limited to use below 500kHz. Above this frequency, accuracy degrades beyond the point of usefulness in instrumentation applications. Additionally, crest factors greater than 10 cause significant reading errors.

A way to achieve wide bandwidth and high crest factor performance is to measure the true power value of the waveform directly. The circuit of Figure 6 does this by measuring the DC heating power of the input waveform.

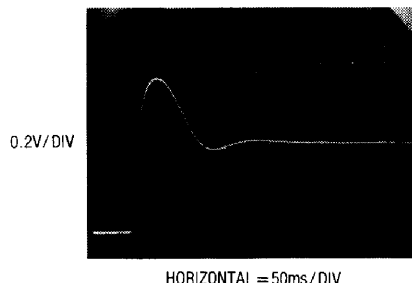

Figure 5. Figure 4's Thermal Loop Response

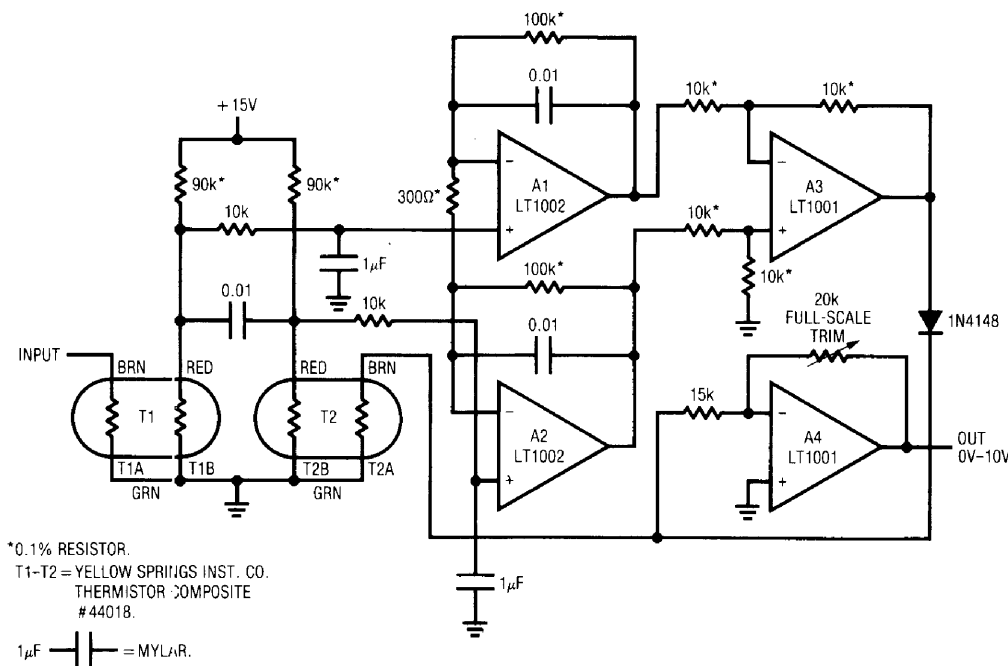

Figure 6. 50MHz Thermal RMS → DC Converter

By using thermal techniques to integrate the input waveform, 50MHz bandwidth is easily achieved with 2% accuracy. Additionally, because the thermal integrator's output is at low frequency, no wideband circuitry is required. The circuit uses standard components and requires no special trimming techniques. It is based on measuring the amount of power required to maintain two similar but thermally decoupled masses at the same temperature. The input is applied to T1, a dual thermistor bead. The power dissipated in one leg (T1A) of this bead forces the other section (T1B) to shift down in value, unbalancing the bridge formed by the other bead and the 90kΩ resistors. This imbalance is amplified by the A1-A2-A3 combination. A3's output is applied to a second thermistor bead, T2. T2A heats, causing T2B to decay in value. As T2B's resistance drops, the bridge balances. A3's output adjusts drive to T2A until T1B and T2B have equal values. Under these conditions, the voltage at T2A is equal to the RMS value of the circuit's input. In fact, slight mass imbalances between T1 and T2 contribute a gain error, which is corrected at A4. RC filters at A1 and A2 and the 0.01μF capacitor eliminate possible high frequency error due to capacitive coupling between T1A and T1B. The diode in A3's output line prevents circuit latch-up.

Figure 7 details the recommended thermal arrangement for the thermistors. The styrofoam block provides an isothermal environment and coiling the thermistor leads attenuates heat pipe effects to the outside ambient. The two inch distance between the devices allows them to see identical thermal conditions without interaction. To calibrate this circuit, apply 10V_{DC} to the input and adjust the full-scale trim for 10 volts out at A4. Accuracy remains within 2% from DC to 50MHz for inputs of 300mV to 10V.

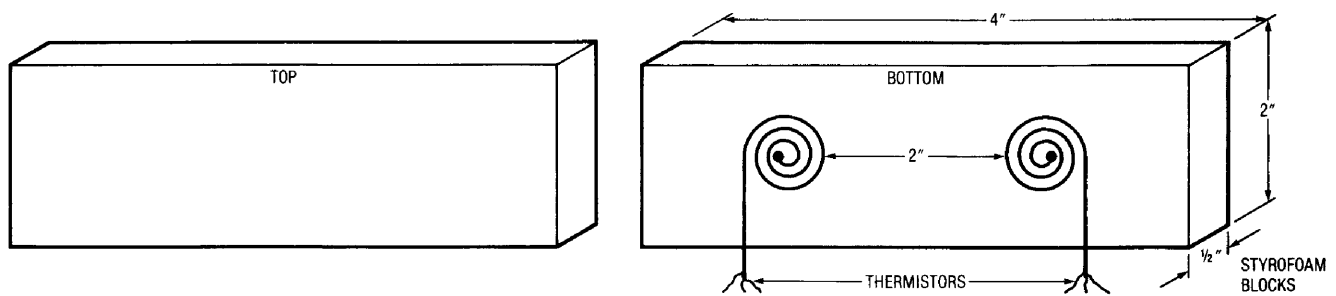

Figure 7. Thermal Arrangement for RMS → DC Converter

Crest factors of 100:1 contribute less than 0.1% additional error and response time to rated accuracy is five seconds.

Low Flow Rate Thermal Flowmeter

Measuring low flow rates in fluids presents difficulties. "Paddle wheel" and hinged vane type transducers have low and inaccurate outputs at low flow rates. If small diameter tubing is required, as in medical or biochemical work, such transduction techniques also become mechanically impractical. Figure 8 shows a thermally based flowmeter which features high accuracy at rates as low as 1mL/minute and has a frequency output which is a linear function of flow rate. This design measures the differential temperature between two sensors (Figure 9). One sensor, T1, located before the heater resistor, assumes the fluid's temperature before it is heated by the resistor. The second sensor, T2, picks up the temperature rise induced into the fluid by the resistor's heating. The sensor's difference signal appears at A1's output. A2 amplifies this difference with a time constant set by the 10MΩ adjustment. Figure 10 shows A2's output versus flow rate. The function has an inverse relationship. A3 and A4 linearize this relationship, while simultaneously providing a frequency output (Figure 10). A3 functions as an integrator which is biased from the LT1004 and the 383k input resistor. Its output is compared to A2's output at A4. Large inputs from A2 force the integrator to run for a long time before A4 can go high, turning on Q1 and resetting A3. For small inputs from A2, A3 does not have to integrate very long before resetting action occurs. Thus, the configuration oscillates at a frequency which is inversely proportional to A2's output voltage. Since this voltage is inversely related to flow rate, the oscillation frequency linearly corresponds to flow rate.

Application Note 5

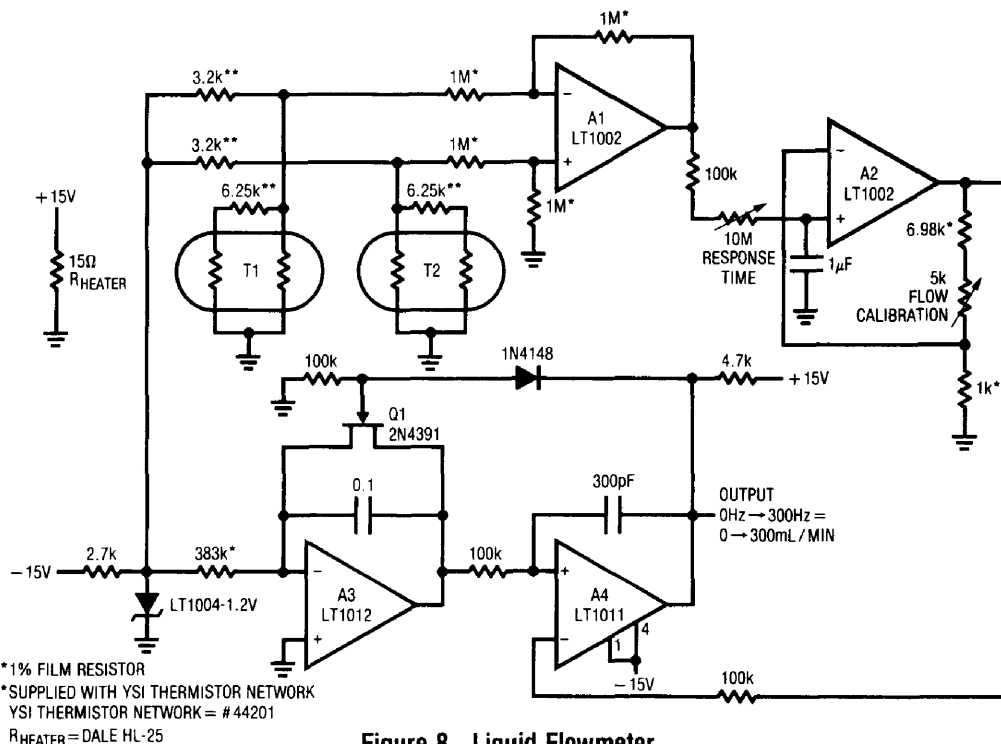

Figure 8. Liquid Flowmeter

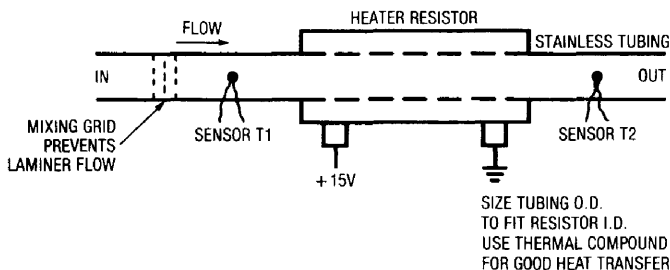

Figure 9. Flowmeter Transducer Details

Several thermal considerations are important in this circuit. The amount of power dissipated into the stream should be constant to maintain calibration. Ideally, the best way to do this is to measure the VI product at the heater resistor and construct a control loop to maintain constant wattage dissipation. However, if the resistor specified is used, its drift with temperature is small enough to assume constant dissipation with a fixed voltage drive. Additionally, the fluid's specific heat will affect calibration. The curves shown are for distilled water. To calibrate this circuit, set a flow rate of 10mL/minute and

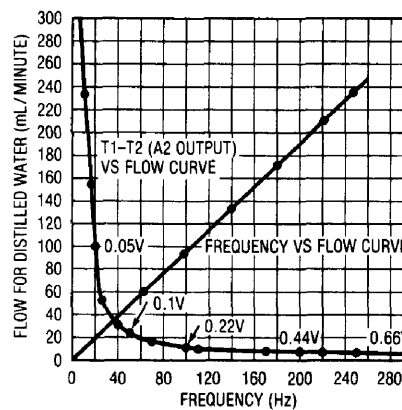

Figure 10. Flowmeter Response Data

adjust the flow calibration trim for 10Hz output. The response time adjustment is convenient for filtering flow aberrations due to mechanical limitations in the pump driving the system.

Thermally Based Anemometer (Air Flowmeter)

Figure 11 shows another thermally based flowmeter, but this design is used to measure air or gas flow. It works by measuring the energy required to maintain a heated resistance wire at constant temperature. The positive temperature coefficient of a small lamp, in combination with

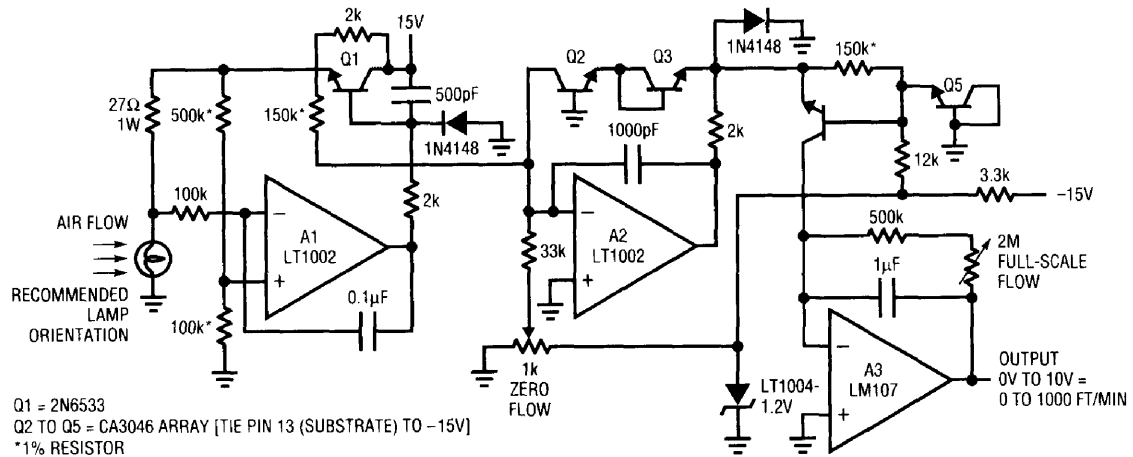

Figure 11. Thermal Anemometer

its ready availability, makes it a good sensor. A type 328 lamp is modified for this circuit by removing its glass envelope. The lamp is placed in a bridge which is monitored by A1. A1's output is current amplified by Q1 and fed back to drive the bridge. The capacitors and 220 Ω resistor ensure stability. The 2k resistor furnishes start-up. When power is applied, the lamp is at a low resistance and Q1's emitter tries to come full on. As current flows through the lamp, its temperature quickly rises, forcing its resistance to increase. This action increases A1's negative input potential. Q1's emitter voltage decreases and the circuit finds a stable operating point. To keep the bridge balanced, A1 acts to force the lamp's resistance, hence its temperature, constant. The 10k-2k bridge values have been chosen so that the lamp operates just below the incandescence point. This high temperature minimizes the effects of ambient temperature shifts on circuit operation. Under these conditions, the only physical parameter which can significantly influence the lamp's temperature is a change in dissipation characteristic. Air flow moving by the lamp provides this change. Moving air by the lamp tends to cool it and A1 increases Q1's output to maintain the lamp's temperature. The voltage at Q1's emitter is non-linearly, but predictably, related to air flow by the lamp. A2, A3 and the array transistors form a circuit which squares and amplifies Q1's emitter voltage to give a linear, calibrated output versus air flow rate. To use this circuit, place the lamp in the air flow so that its filament is at a 90° angle to the flow. Next, either shut off the air flow or shield the lamp from it and adjust the zero flow potentiometer for a circuit output of 0V. Then, expose the lamp to air flow of 1000 feet/minute and trim the full flow potentiometer for 10V output.

Repeat these adjustments until both points are fixed. With this procedure completed, the air flowmeter is accurate within 3% over the entire 0-1000 foot/minute range.

Low Distortion, Thermally Stabilized Wien Bridge Oscillator

The positive temperature coefficient of lamp filaments is employed in a modern adaptation of a classic circuit in Figure 12. In any oscillator it is necessary to control the gain as well as the phase shift at the frequency of interest. If gain is too low, oscillation will not occur. Conversely, too much gain will cause saturation limiting. Figure 12 uses a variable Wien Bridge to provide frequency tuning from 20Hz to 20kHz. Gain control comes from the positive temperature coefficient of the lamp. When power is applied, the lamp is at a low resistance value, gain is high and oscillation amplitude builds. As amplitude builds, the lamp current increases, heating occurs and its resistance goes up. This causes a reduction in amplifier gain and the circuit finds a stable operating point. The lamp's gain-regulating behavior is flat within 0.25dB over the 20Hz-20kHz range of the circuit. The smooth, limiting nature of the lamp's operation, in combination with its simplicity, gives good results. Trace A, Figure 13 shows circuit output at 10kHz. Harmonic distortion is shown in Trace B and is below 0.003%. The trace shows that most of the distortion is due to second harmonic content and some crossover disturbance is noticeable. The low resistance values in the Wein network and the 3.8nV $\sqrt{\text{Hz}}$ noise specification of the LT1037 eliminate amplifier noise as an error term.

Application Note 5

At low frequencies, the thermal time constant of the small normal mode lamp begins to introduce distortion levels above 0.01%. This is due to "hunting" as the oscillator's frequency approaches the lamp thermal time constant. This effect can be eliminated, at the expense of reduced output amplitude and longer amplitude settling time, by switching to the low frequency, low distortion mode. The four large lamps give a longer thermal time constant and distortion is reduced. Figure 14 plots distortion versus frequency for the circuit.

References

1. Multiplier Application Guide, pp. 7-9, "Flowmeter," Analog Devices, Inc., Norwood, Massachusetts.

2. Olson, J. V., "A High Stability Temperature Controlled Oven," S.B. Thesis M.I.T., Cambridge, Massachusetts, 1974.

3. PIN Photodiodes—5082-4200 Series, pp. 332-335, Optoelectronics Designers' Catalog, 1981, Hewlett Packard Company, Palo Alto, California.

4. Y.S.I. Thermilinear Thermistor, # 44018 Data Sheet, Yellow Springs Instrument Company, Yellow Springs, Ohio.

5. Hewlett, William R., "A New Type Resistance-Capacity Oscillator," M.S. Thesis, Stanford University, Palo Alto, California, 1939.

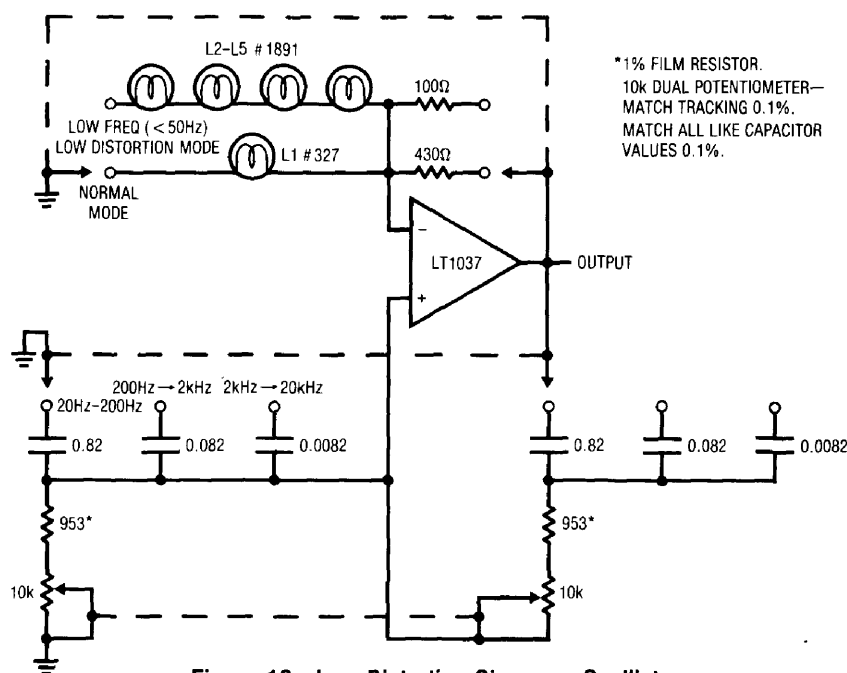

Figure 12. Low Distortion Sinewave Oscillator

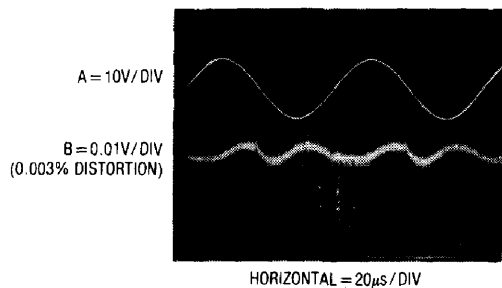

Figure 13. Oscillator Waveforms

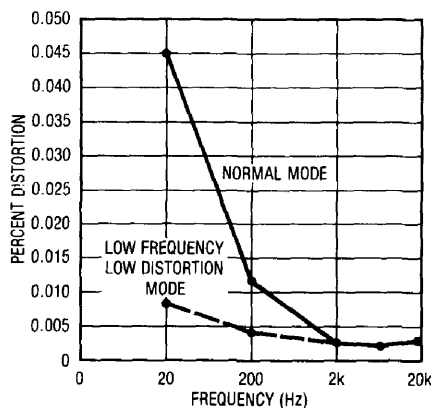

Figure 14. Oscillator Distortion vs Frequency